

Installation Manual and Operating Instructions

TRUE BLUE POWER

TFC4000 SERIES

FREQUENCY
CONVERTER

Manual Number
9019509



Revision E • September 12, 2024

FOREWORD

This manual provides information intended for use by persons who, in accordance with current regulatory requirements, are qualified to install this equipment. If further information is required, please send inquiries per the contact information below.

We welcome your comments concerning this manual. Although every effort has been made to keep it free of errors, some may occur. When reporting a specific problem, please describe it briefly and include the manual part number, the paragraph/figure/table number and the page number. Send your comments to:

True Blue Power
c/o Mid-Continent Instrument Co., Inc.
Attn: Engineering
9400 E. 34th St. N.
Wichita, KS 67226 USA

Phone 316-630-0101
Email mcia@mcico.com

Or, visit us on the web at:
www.truebluepowerusa.com
www.mcico.com



Download the current version of this installation manual using your smartphone or tablet.

TABLE OF CONTENTS

<u>SECTION 1</u>	<u>GENERAL DESCRIPTION</u>	<u>4</u>
1.1	INTRODUCTION	4
1.2	TECHNICAL SPECIFICATIONS	5
<u>SECTION 2</u>	<u>PRE-INSTALLATION CONSIDERATIONS</u>	<u>6</u>
2.1	COOLING	6
2.2	EQUIPMENT LOCATION	6
2.3	ROUTING OF CABLES	6
2.4	LIMITATIONS	6
2.5	MODIFICATION	7
<u>SECTION 3</u>	<u>INSTALLATION</u>	<u>8</u>
3.1	GENERAL INFORMATION	8
3.2	UNPACKING AND INSPECTING EQUIPMENT	8
3.3	CABLE HARNESS	8
3.4	MOUNTING	12
3.5	INSTALLATION CAUTIONS	12
3.6	INSTALLATION COMPLETION	12
<u>SECTION 4</u>	<u>OPERATION</u>	<u>14</u>
4.1	ELECTRICAL PERFORMANCE	14
4.2	PROTECTIVE FEATURES	14
<u>SECTION 5</u>	<u>CONFORMANCE</u>	<u>16</u>
5.1	INSTRUCTIONS FOR CONTINUED AIRWORTHINESS	16
5.2	ENVIRONMENTAL QUALIFICATION STATEMENT	16

REVISION HISTORY

Rev	Date	Detail	Approved
A	11/04/2022	Initial release.	CAS
B	07/06/2023	Added DC Offset protection and FAA-PMA certification. Updated weight from 19.8 to 18.9.	CAS
C	12/15/2023	Added info regarding TSO-C230. Clarified polarity of Fault Status in 3.3.2.5. Updated qualifications table in 5.2.	CAS
D	07/12/2024	Updated Environmental Qualification Statement.	CAS
E	09/12/2024	Addition of TFC4002.	ESH

SECTION 1 GENERAL DESCRIPTION

1.1 INTRODUCTION

The model TFC4000 Series Frequency Converters are high-reliability, lightweight frequency converters that provide 4000 volt-amperes (4kVA) of power from a 115/200 VAC, 3 phase, 360-800 Hertz (Hz) input to either 115VAC or 230VAC single phase output per below:

Configurations			
Model	Part Number	Output	Typical Application
TFC4000	6434000-1	115 VAC, 60 Hz	General Purpose 115V cabin power
TFC4002	6434000-2	230 VAC, 50 Hz	General purpose 230V cabin power

Table 1.1

All configurations of the Model TFC4000 Series provide 4000 VA (Volt-Amperes) of output power. The alternating current output is defined as a single-phase, pure sine wave with less than 3% of total harmonic distortion for clean, noise-free power to supply loads of corresponding voltage, power, and frequency. For the TFC4000, the 115 VAC / 60 Hertz (Hz) is suitable for nearly any common commercial or consumer load rated for a nominal input of 115 VAC. The TFC4002 is designed for a 230 VAC / 50 Hz output for any equipment designed to accept this voltage.

The TFC4000 Series Frequency Converters are FAA certified to TSO-C230 and tested to rigorous environmental standards and levels of RTCA DO-160G. The TFC4000 Series provides higher power in a lighter package than any available certified equivalent in the aviation industry. It is designed specifically with harsh environments in mind, incorporating a robust and unique approach that protects and cools the electronics from the elements and high temperatures. Its installation flexibility allows for it to be located inside or outside the pressure vessel. At the same time, it can also be installed where acoustic noise suppression is critical, with the quietest operation of any competitive product.

This makes the TFC4000 Series an ideal choice for aircraft power needs while reducing the challenges associated with traditional solutions used for the same function.

Highlighted features include short circuit protection, overload capability, low voltage shut-down, temperature monitoring, a self-resettable over-temperature shutoff, and a remote on/off function. The rugged extrusion that supports the unit is designed to help dissipate heat and provide mechanical strength against vibration or other possibilities of damage. Three independent fans allow for a smaller unit, quiet operation, and no need for external cooling; keeping the internal components at a lower operational temperature and thus extending the life of the unit.

1.2 TECHNICAL SPECIFICATIONS

Electrical Attributes		
	6434000-1	6432000-2
Input Voltage:	115/200 VAC 3 phase, 360 Hz - 800 Hz	
Input Power:	13.2-15.0 A (over 360 – 800 Hz)	
Output Voltage: (single phase)	115VAC ±3% at 60 Hz ±0.5%	230VAC ±3% at 50 Hz ±1.5%
Output Power:	4000 VA, 4 kW at power factor = 1	
Output Waveform:	Single phase pure sine wave	
Power Factor:	-0.8 to +0.8	
Efficiency:	93% nominal	
Total Harmonic Distortion:	< 3%	
Fault Output:	Discrete GND/open, 100 mA maximum	

Table 1.2

Physical Attributes	
Weight:	18.9 pounds (not to exceed +5%)
Dimensions:	15.7 inches long x 7.0 inches wide x 5.0 inches high (excludes mating connectors)
Mating Connector: (and cable clamp)	MCIA P/N 9019110-4 and 9019507-2
Mounting:	Base mount; orientation not critical

Table 1.3

Qualifications	
Certification:	FAA TSO-C230, FAA PMA
Environmental Qualification:	RTCA DO-160G Environmental Category; See Section 5.2
Altitude:	+55,000 ft
Temperature:	-40 °C to +75 °C (-40 °F to +167 °F)

Table 1.4

SECTION 2 PRE-INSTALLATION CONSIDERATIONS

2.1 COOLING

No external cooling is required. The unit is equipped with three internal DC fans. Restriction to airflow can cause overheating of the unit and limit performance or reduce the expected life of the product. Make sure to provide adequate clearance on both ends of the unit with the hexagonal openings to allow for proper circulation. In general, four to six inches of clearance on both ends of the unit should be acceptable. Mounting the unit to a metal surface can also help reduce the effects of temperature within the unit but is not required.

2.2 EQUIPMENT LOCATION

The TFC4000 Series Frequency Converters are designed for mounting flexibility, allowing for installation inside or outside the pressure vessel with no requirement for temperature control. In addition to altitude and temperature resistance, the units are also designed to withstand high levels of condensing humidity.

Installation locations where the unit could be subject to standing or direct water exposure should be avoided. The unit can be mounted in any orientation. Clearance should be provided for the mating connector and may require as much as five inches past the unit connector to allow for back shell access to the connector.

2.3 ROUTING OF CABLES

The wires and cable bundle associated with the unit are heavy gauge wire and carry significant power. Be aware of routing cables near other electronics or with other wire bundles that may be susceptible to high energy flow.

Avoid sharp bends in cabling and routing near aircraft control cables. Also avoid proximity and contact with aircraft structures, avionics equipment, or other obstructions that could chafe wires during flight and cause undesirable effects.

2.4 LIMITATIONS

The TFC4000 Series Frequency Converters are certified to FAA TSO-C230.

The conditions and tests for TSO approvals of these articles are minimum performance standards. Those installing these articles, on or in a specific type or class of aircraft, must determine that the aircraft installation conditions are within the TSO standards, and specification of the article. TSO articles must have separate approval for installation in an aircraft. The article may be installed only according to 14 CFR part 43 or the applicable airworthiness requirements.

2.5 MODIFICATION

This product has a nameplate that identifies the manufacturer, part number, description, certification(s) and technical specifications of the unit. It also includes the “MOD” or modification number representing notable changes in the hardware design of the unit.

Modification (MOD) 0 is the initial release of the product and is identified on the nameplate by the lack of marking on the MOD numbers 1 through 9 (i.e. 1-9 are visible). All subsequent modifications are identified on the nameplate by the marking/blacking out of that particular MOD number (i.e. for MOD 1, the number 1 is not visible and 2-9 are visible - see Figure 2.1 for examples). MODs do not have to be sequentially inclusive and may be applied independent of each other.

For additional details regarding specific changes associated with each MOD status refer to the product published Service Bulletins at www.truebluepowerusa.com.

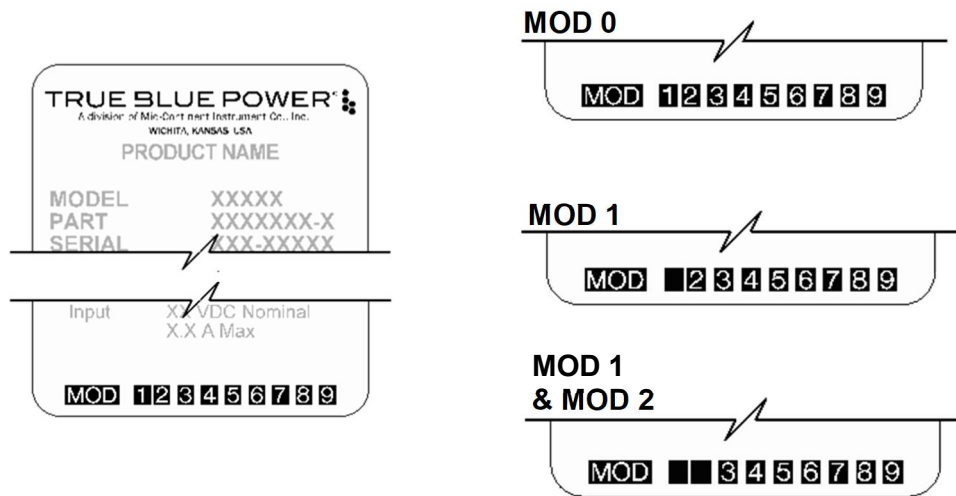

Figure 2.1
Nameplate and MOD Status Example

SECTION 3 INSTALLATION

3.1 GENERAL INFORMATION

This section contains interconnect diagrams, mounting dimensions and other information pertaining to the installation of the TFC4000 Series Frequency Converter. After installation of cabling and before installation of the equipment, ensure that power is applied only to the pins specified in the interconnect diagram.

3.2 UNPACKING AND INSPECTING EQUIPMENT

When unpacking this equipment, make a visual inspection for evidence of any damage that may have occurred during shipment.

The following parts should be included:

- | | |
|------------------------|----------------------|
| A. Frequency Converter | MCIA P/N 6434000-() |
| B. Installation Manual | MCIA P/N 9019509 |

Available Equipment:

- | | |
|---------------------------------------|----------------------------------|
| A. Mating Connectors (& cable clamps) | MCIA P/N 9019110-4 and 9019507-2 |
|---------------------------------------|----------------------------------|

Equipment not provided:

- | | |
|-----------------------|---|
| A. Cable Harness Wire | See Section 3.3 for specifications |
| B. Mounting Hardware | eight (8) ¼-20 bolts or pan head screws
¼" lock washers (optional) |

3.3 CABLE HARNESS

Construct the cable harness with regard to the instructions below, and using the Connector Pinout of Figure 3.1, Table 3.1, and Wiring Diagram of Figure 3.2.

Refer to Section 2: Pre-Installation Considerations regarding routing precautions.

3.3.1 Wire Gauge Selection

Use of PTFE, ETFE, TFE, Teflon, or Tefzel insulated wire is recommended for aircraft use.

The following wire gauges are recommended for each of the pins in the connector:

5-Pin Connector (MS3102A18-11P):

Pins A, B, C, D, E - 12 AWG stranded

9-Pin Connector (MS3102A24-11S):

Pins A, B, C, G - 22 AWG stranded

Pins D, E, F - 8 AWG stranded

3.3.2 Pin Assignment Information

3.3.2.1 Input Power, Wye Configuration Required

- (5-Pin Connector, Pin A) Positive AC, Phase A input – 115/200 VAC, 360-800 Hz
- (5-Pin Connector, Pin B) Positive AC, Phase B input – 115/200 VAC, 360-800 Hz
- (5-Pin Connector, Pin C) Positive AC, Phase C input – 115/200 VAC, 360-800 Hz
- (5-Pin Connector, Pin D) Neutral, Required
- (5-Pin Connector, Pin E) Chassis GND
 - This pin is connected to the internal structure. Note that the anodized cover is not considered to be conductive.
 - Connect to aircraft structure close to the unit.

3.3.2.2 Converter Output

- (9-Pin Connector, Pin D) AC Output – 115 VAC, 60Hz, 4.0 kVA (TFC4000), or 230 VAC, 50Hz, 4.0 kVA (TFC4002)
 - Used for powering devices where terrestrial/utility power designations are used.
 - Connect this pin as “Line” or “Hot”.
- (9-Pin Connector, Pin E) AC Return
 - Used for powering devices where terrestrial/utility power designations are used.
 - Connect this pin as “Neutral”.
- (9-Pin Connector, Pin F) Chassis GND
 - This pin is connected to the internal structure. Note that the anodized cover is not considered to be conductive.
 - Connect to aircraft structure close to the unit.

3.3.2.3 Circuit Breakers on Input Power

- Circuit breakers should be rated at the maximum fault current (150% overload)
- A 30 Ampere circuit breaker is recommended on the AC input

3.3.2.4 Converter Remote On/Off Control (see section 4.2.1)

- (9-Pin Connector, Pin A) Remote ON/OFF Enable Control
 - Connect this pin either through a remote switch or permanently to Pin B to enable the AC output of the inverter.
 - This pin is internally pulled to 12 VDC with a limit of 1 mA.
- (9-Pin Connector, Pin B) Remote Return
 - Should be twisted with Pin A wire and grounded to aircraft structure at the switch, or connected to aircraft structure close to the unit.

3.3.2.5 Fault Status

- (9-Pin Connector, Pin C) Fault
 - Grounded output signal, typically connected to an indicating LED or lamp. Pin C will be low (same as Pin G) when the unit is operating normally. Pin C will be open (internally pulled up by 22k to 12V) when a fault is present.
- (9-Pin Connector, Pin G) Fault Return
 - Should be twisted with Pin C wire and grounded to aircraft structure at the indicator, or connected to aircraft structure close to the unit.

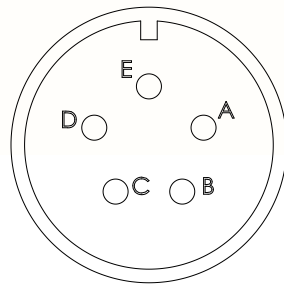

5-Pin Connector Pinout	
Pin #	
A	Input phase A
B	Input phase B
C	Input phase C
D	Neutral
E	Chassis GND

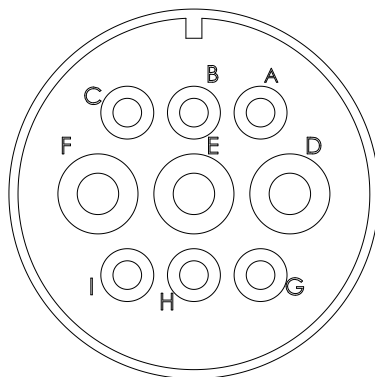

9-Pin Connector Pinout	
Pin #	
A	Remote, On/Off
B	Remote Return
C	Fault
D	AC Output
E	AC Return
F	Chassis GND
G	Fault Return
H	Spare
I	Spare

Figure 3.1

Pinout View of Unit Connectors
5-Pin (MS3102A18-11P)
9-Pin (MS3102A24-11S)

Table 3.1

Connector Pinout

3.3.3 Use with GFCI, and Other Earth/Neutral Situations

The TFC4000 Series of converters is fully electrically isolated from the AC input and provides a balanced AC output where AC output and AC return are not associated with the Chassis GND. This is different from terrestrial AC systems where Neutral is connected to ground at an AC distribution transformer at the power mains.

Some consumer items contain internal power supplies that require an Earth-Neutral connection for their noise filters to work properly. Similarly, some GFCI protection will not function properly if there is not an Earth/Neutral connection or if there is noise between Earth and Neutral.

If there is not a GFCI, the AC Output and AC Return should not be tied to Chassis GND. If a GFCI is used, the output AC Return (Neutral) should be tied to Chassis GND at the unit or the GFCI box.

3.3.4 Wiring Examples

The wiring diagram of Figure 3.2 provides general examples of typical installations. The configuration of individual aircraft installations may vary.

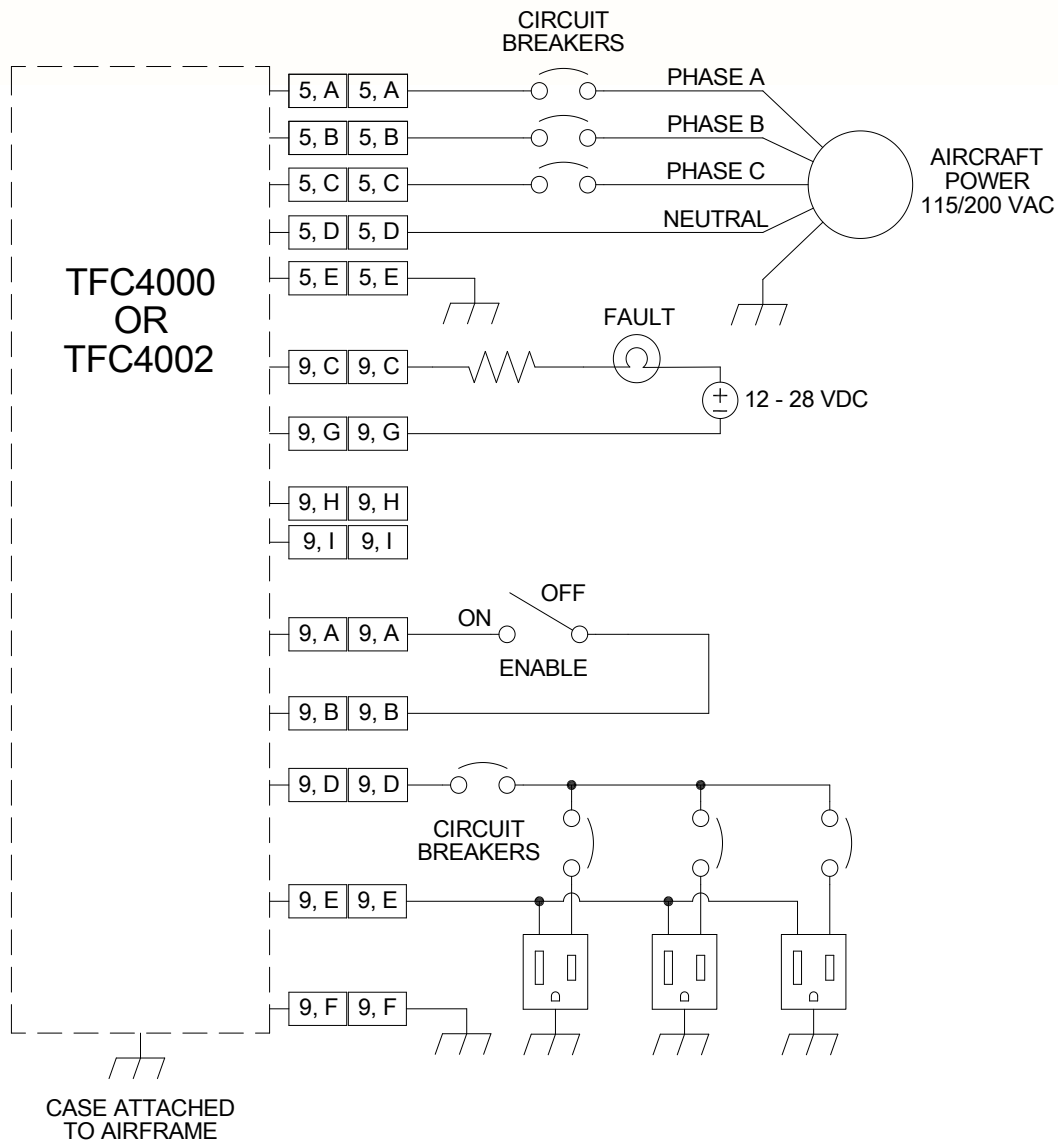

Figure 3.2
Example Wiring Diagrams

3.3.5 Harness Verification

With the TFC4000 Series Frequency Converter disconnected, activate the aircraft power bus that supplies the unit and use a multi-meter to verify that aircraft power and ground with appropriate voltage is on the pins within the mating harness.

3.4 MOUNTING

Refer to Section 2: Installation Considerations regarding equipment location.

The TFC4000 Series Frequency Converter is designed for base mounting only (in any orientation). The unit includes eight (8) threaded mounting holes for securing it to the aircraft. Eight thru holes for ¼-20 bolts or screws should be provided in the aircraft in accordance with Figure 3.3. Secure the unit with eight ¼-20 bolts, pan head Phillips screws, or equivalent.



Screws/bolts must not extend into the unit more than 0.3 inches MAX.

A lock-washer under the head of each screw is recommended.

3.5 INSTALLATION CAUTIONS



The TFC4000 Series converters do not have the ability to phase sync the output to other AC power sources. Do not connect the output of the TFC4000 Series to any other converter or AC source, including another TFC4000 unit, or damage to the unit will result.

As noted in Section 3.3.3, the TFC4000 Series has a balanced AC output that is not referenced to Chassis GND. If a digital meter is used to measure the AC output relative to Chassis GND, the measurement may erroneously show up to half of the converter rated output voltage. This voltage is not a problem and is the result of making a high-impedance measurement of AC voltages.

3.6 INSTALLATION COMPLETION

Prior to operating the unit in the aircraft, it is recommended to verify the output and functionality of the unit. In order to prevent accidental damage to other systems, it is best not to attach the output to other equipment or power buses prior to verification.

Verify the output of the unit at the terminating end of the cable with a multi-meter to ensure proper voltage and polarity. Once verified, installation can be completed, and functionality of the remote on/off feature (if used) should be checked.

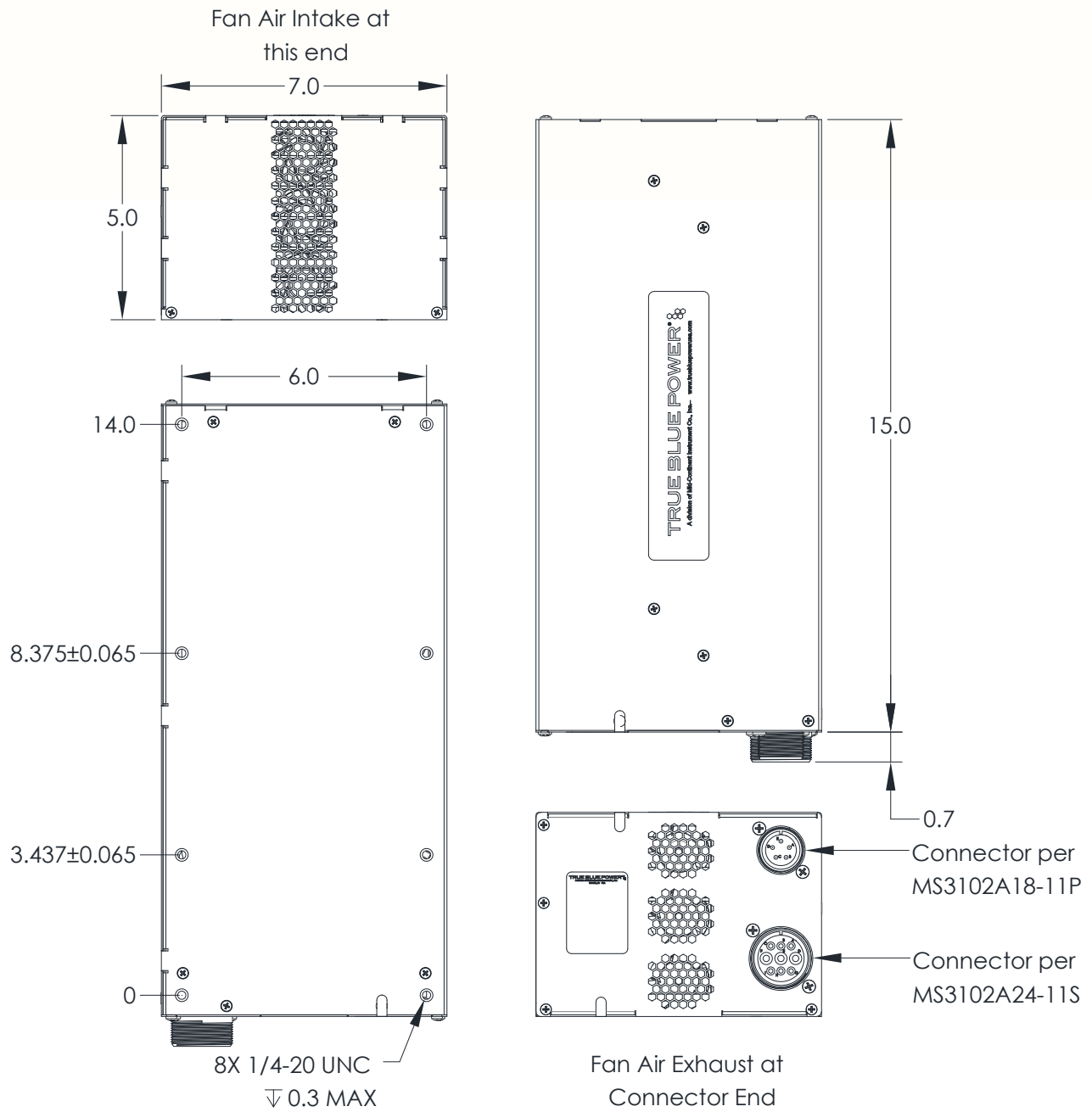

Figure 3.3
TFC4000 Series Outline Drawing

SECTION 4 OPERATION

4.1 ELECTRICAL PERFORMANCE

The TFC4000 Series Frequency Converters converts three-phase 115 VAC at 360 to 800 Hz into single-phase 115 VAC, 60 Hz (TFC4000) or 230 VAC, 50Hz, (TFC4002). The units are capable of providing 4000 VA (4 kW at power factor = 1) to power outlets that can support a variety of aircraft and consumer electronics and appliances including laptops, computer systems, TVs, vacuums, and many others (See Table 1.2 for tolerance ranges). The output power can also be hard-wired to permanently installed equipment on the aircraft, if required.

The unit is designed as a three-stage, solid-state switch-mode power supply. The front end is Bridgeless Power-Factor-Correction (PFC) circuit with Boost topology. The second stage utilizes a power transformer for conversation, isolation, and step down to a DC voltage. The final stage contains an H-bridge AC inverter to provide the single-phase output. All the three stages utilize 'current-mode' control providing instantaneous load protection.

4.2 PROTECTIVE FEATURES

4.2.1 Remote On/Off

The TFC4000 Series Frequency Converters incorporates a remote on/off feature that allows the user to enable or disable the output of the unit. By providing a ground on the appropriate pin (See Table 3.1) the user, via a remote mounted switch or similar method, can enable the output of the unit. The unit can be similarly disabled by removing the ground signal (open circuit) to the same pin.

4.2.2 Over-Voltage

When the input voltage exceeds the operating range of the unit (See Table 1.2; absolute maximum input of 134 VAC/232VAC) the unit senses an over-voltage condition and disables the output. The unit will dynamically monitor the input voltage such that if the input returns to within the normal operating range, the output will be enabled and allow the unit to operate normally.

4.2.3 Under-Voltage

When the input voltage drops below the operating range of the unit (See Table 1.2; absolute minimum input of 97 VAC/168 VAC) the unit senses an under-voltage condition and disables the output. The unit will monitor the input voltage such that if the input returns to within the normal operating range, the output will be enabled and allow the unit to operate normally.

4.2.4 Over-Temperature

The TFC4000 Series incorporates an internal temperature sensing device that provides monitoring and feedback to the control circuits. When the unit senses an internal condition that exceeds maximum temperature, the converter output is disabled, and the internal cooling fans will continue to operate. The unit output will be enabled when the temperature returns to within acceptable limits. This over-temperature reset occurs automatically without any external intervention required.

4.2.5 Short Circuit and Over-Current

The TFC4000 Series is capable of surviving a short circuit or over-current event without permanent damage or effect to long-term reliability. The unit can provide over its rated power output up to 125% of rating or 5000 VA continuously if the ambient is low enough not to trip the thermal protection. The unit can provide over its rated power output up to 150% of rating or 6000 VA for 5 minutes, before an internal timer interrupts its output and Fault pin goes high impedance. The enable pin will need to be reset to TURN ON the unit. The unit can provide over its rated power output up to 200% of rating or 8000 VA for 5 seconds before an internal timer interrupts its output and Fault pin goes high impedance. The enable pin will need to be reset to TURN ON the unit.

At full short circuit, the unit detects abnormal conditions and limits output Current to 54 A peak for the TFC4000 and 27 A peak for the TFC4002. If the short circuit is removed within 2 seconds, the converter will return to full power, otherwise the output will shut off until the enable or the power input is cycled off and on again.

4.2.6 Temperature Regulated Cooling

The unit is equipped with three internal brushless DC fans for cooling to extend the power range and ensure long-term reliability and life. The fans are thermostatically controlled and are only activated dependent on the continuous monitoring and feedback of the internal temperature. When active, the fans are controlled via variable speed as needed to reduce acoustic noise. Similarly, the fans are limited to half-speed if the output is not enabled or the unit goes into thermal shutdown. The fans operate very quietly to reduce the audible noise in any environment. The three fans provide independent redundancy for protection of the unit in the event that one becomes inoperative.

4.2.7 Output DC Offset

The TFC4000 Series regulates its DC offset within +/- 100 mV. The TFC4000 Series incorporates an internal DC offset sensing circuit that provides monitoring and feedback to the control circuits. When the unit senses DC offset more than +/-1 V, the converter output is disabled and latched. The enable pin will need to be reset to TURN ON the unit.

SECTION 5 CONFORMANCE

5.1 INSTRUCTIONS FOR CONTINUED AIRWORTHINESS

No periodic scheduled maintenance or calibration is necessary for continued airworthiness of the TFC4000 Series Frequency Converters. If the unit fails to perform to specifications, the unit must be removed and serviced by Mid-Continent Instruments and Avionics or their authorized designee.

5.2 ENVIRONMENTAL QUALIFICATION STATEMENT

MODEL NUMBER: TFC4000, TFC4002 **PART NUMBER:** 6434000-() Series
DESCRIPTION: Frequency Converter, 4 kVA **CERTIFICATION:** FAA TSO-C230, PMA
MANUFACTURER: True Blue Power, a division of Mid-Continent Instrument Co., Inc.
ADDRESS: 9400 E. 34th St. North, Wichita, KS 67226, USA.
SPECIFICATION: Test Specification (TS) 796, Test Data Sheet (TDS) 796
STANDARD: RTCA DO-160, Rev G, dated 12/08/10

DESCRIPTION OF TEST	SECTION	CATEGORY
Temperature and Altitude	4	Category F1
Temperature Variation	5	Category S2
Humidity	6	Category B
Operational Shock and Crash Safety	7	Category B (5R)
Vibration	8	Category R; Curve C, C1
Explosion	9	Category E
Waterproofness	10	Category W
Fluids	11	Category F
Sand and Dust	12	Category D
Fungus	13	Category F
Salt Spray	14	Category X
Magnetic Effect	15	Category Z
Power Input	16	Category A(CF), A(WF)
Voltage Spike	17	Category B
Audio Frequency Conducted Susceptibility	18	Category R(WF)
Induced Signal Susceptibility	19	Category AC
Radio Frequency Susceptibility	20	Category TT
Emission of Radio Frequency Energy	21	Category B
Lightning Induced Transient Susceptibility	22	Category A3G3L3
Lightning Direct Effects	23	Category X
Icing	24	Category B
ESD	25	Category A
Flammability	26	Category C

Remarks:

*Section 4: Category F1 with exceeded parameters per the following:
 • Operating High: +75°C • Operating Low: -40°C
 • Short-time Operating High: +80°C • Ground Survival High: +95°C
 Section 11: Cleaning (isopropyl alcohol), De-icing (ethylene glycol), Fire Retardant (Halon 1211), Hydraulic (Skydrol)
 Section 13: Category F by analysis
 Section 26: Category C by analysis